

CJ3415-HF (P-Channel)

Reverse Voltage: - 20 Volts

Forward Current: - 4 A

RoHS Device

Halogen Free

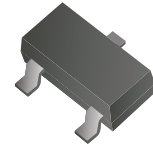

V _{(BR)DSS}	R _{DS(ON)MAX}	I _D
-20V	50mΩ@-4.5V	-4A
	60mΩ@-2.5V	
	73mΩ@-1.8V	

Features

- Extremely low R_{DS(ON)}
- Low gate charge, low gate voltages

Mechanical data

- Case: SOT-23, molded plastic.
- Terminals: Solderable per MIL-STD-750, method 2026.

Circuit diagram

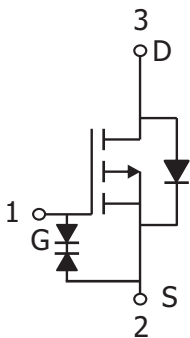

1. G : Gate
2. S : Source
3. D : Drain

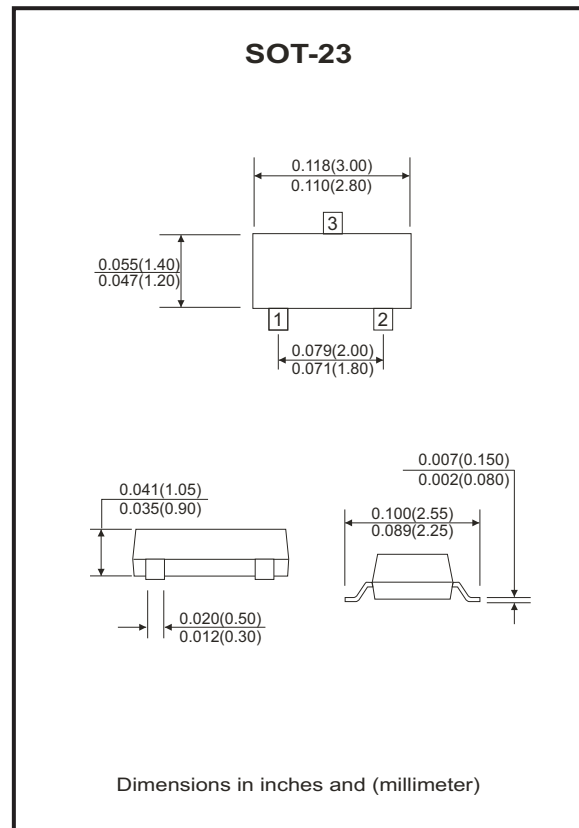

Maximum Ratings (at Ta=25 °C unless otherwise noted)

Parameter	Symbol	Value	Unit
Drain-source voltage	V _{DS}	-20	V
Gate-source voltage	V _{GS}	±8	V
Continuous drain current (t≤10s)	I _D	-4.0	A
Maximum power dissipation (t≤10s)	P _D	0.35	W
Thermal resistance from junction to ambient	R _{θJA}	357	°C/W
Operating junction temperature range	T _J	-40 to +150	°C
Storage temperature range	T _{STG}	-55 to +150	°C

Electrical Characteristics (at TA=25°C unless otherwise noted)

Parameter	Symbol	Conditions	Min	Typ	Max	Units
Static Parameters						
Drain-source breakdown voltage	$V_{(BR)DSS}$	$V_{GS}=0V, I_D=-250\mu A$	-20			V
Gate threshold voltage	$V_{GS(th)}$	$V_{DS}=V_{GS}, I_D=-250\mu A$	-0.3		-1	
Gate-body leakage current	I_{GSS}	$V_{DS}=0V, V_{GS}=\pm 8V$			± 10	μA
		$V_{DS}=0V, V_{GS}=\pm 4.5V$			± 1	
Zero gate voltage drain current	I_{DSS}	$V_{DS}=-16V, V_{GS}=0V$			-1	
Drain-source on-state resistance (note 1)	$R_{DS(on)}$	$V_{GS}=-4.5V, I_D=-4A$			0.050	Ω
		$V_{GS}=-2.5V, I_D=-4A$			0.060	
		$V_{GS}=-1.8V, I_D=-2A$			0.073	
Forward transconductance (note 2)	g_{FS}	$V_{DS}=-5V, I_D=-4A$	8			S
Body diode voltage (note 2)	V_{SD}	$I_S=-1A, V_{GS}=0V$			-1	V
Dynamic Parameters (note 3)						
Input capacitance	C_{iss}	$V_{DS}=-10V, V_{GS}=0V, f=1MHz$		1450		μF
Output capacitance	C_{oss}			205		
Reverse transfer capacitance	C_{rss}			160		
Gate resistance	R_g	$V_{DS}=0V, V_{GS}=0V, f=1MHz$		6.5		Ω
Switching Characteristics						
Total gate charge	Q_g	$V_{DS}=-10V, V_{GS}=-4.5V, I_D=-4A$		17.2		nC
Gate-Source charge	Q_{gs}			1.3		
Gate-drain charge	Q_{gd}			4.5		
Turn-on delay time (note3)	$t_d(on)$	$V_{DS}=-10V, V_{GS}=-4.5V$ $R_{GEN}=3\Omega, R_L=2.5\Omega$		9.5		nS
Turn-on rise time (note3)	t_r			17		
Turn-off delay time (note3)	$t_d(off)$			94		
Turn-off fall time (note3)	t_f			35		

Notes:

1. Repetitive rating, pulse width limited by junction temperature.
2. Pulse test: Pulse width $\leq 300\mu s$, duty cycle $\leq 2\%$
3. These parameters have no way to verify

TYPICAL CHARACTERISTIC

Fig.1 - Output Characteristics

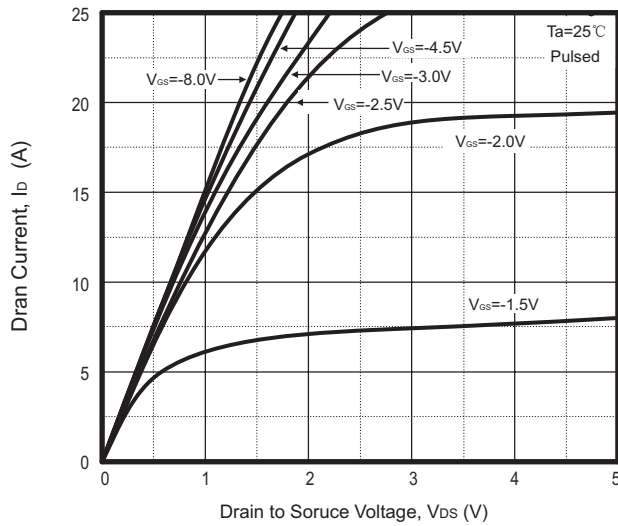

Fig.2 - Transfer Characteristics

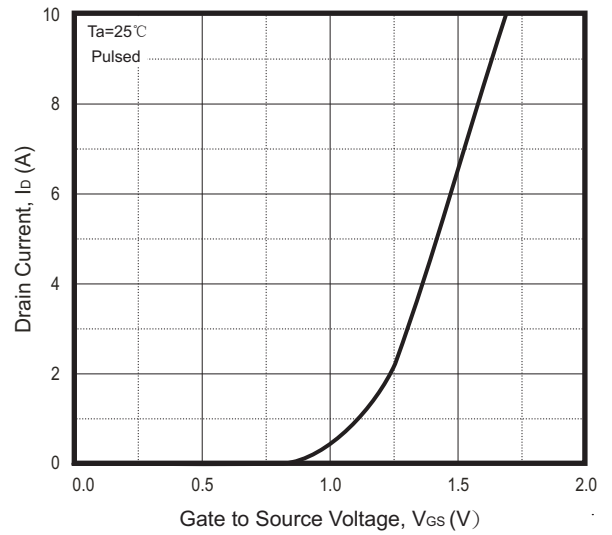

Fig.3 - $R_{DS(ON)} - I_D$

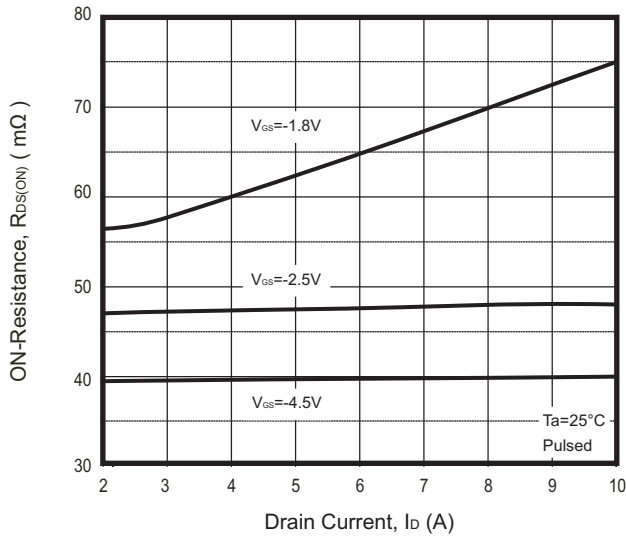

Fig.4- $R_{DS(ON)} - V_{GS}$

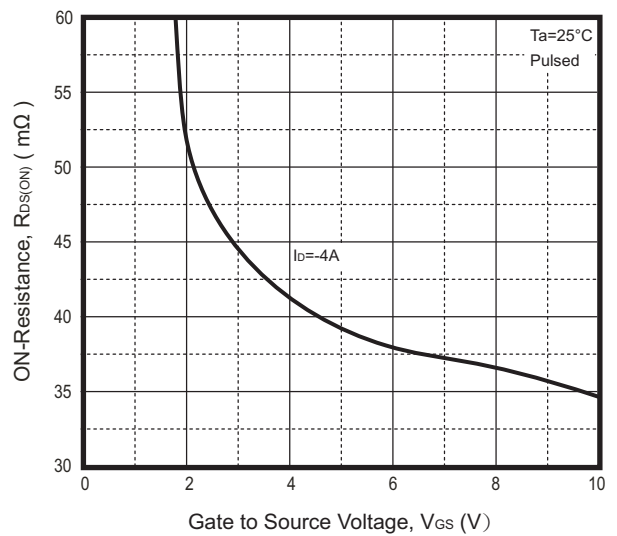
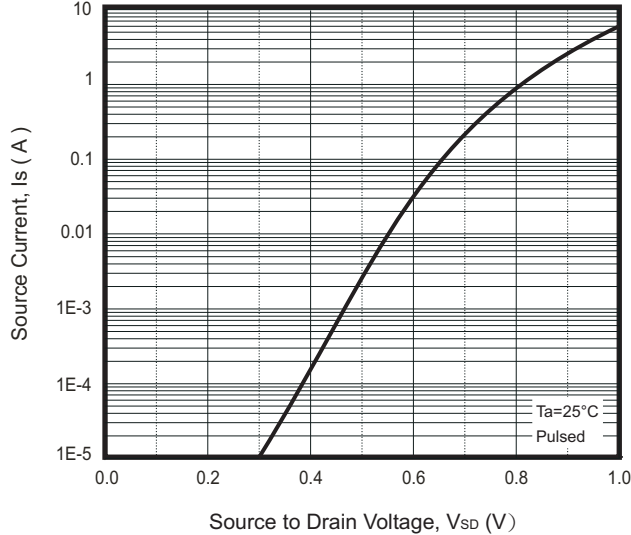
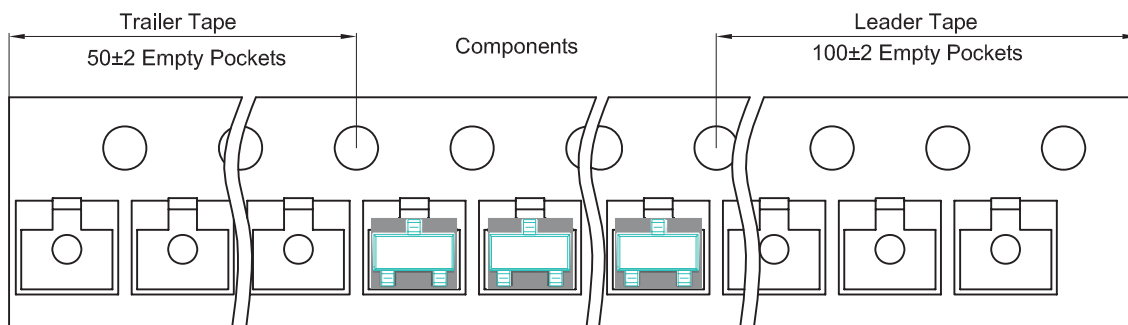
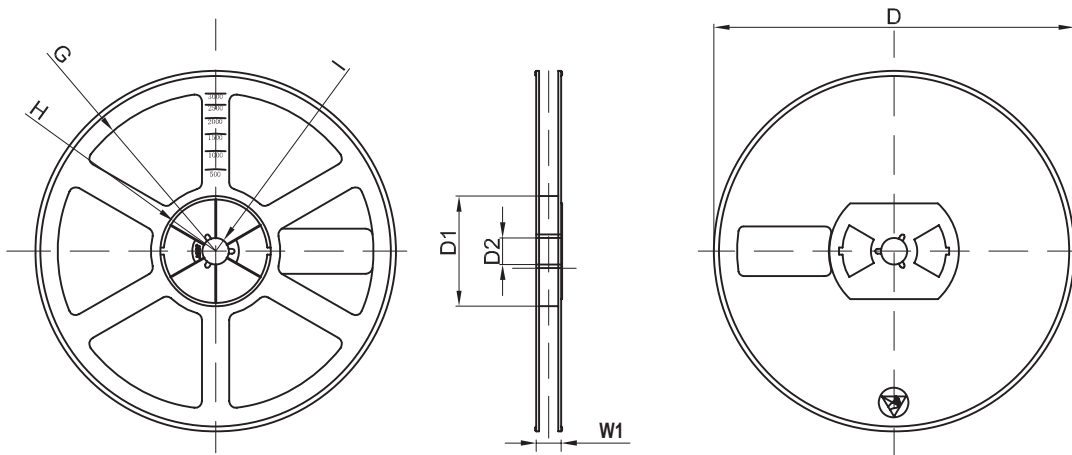
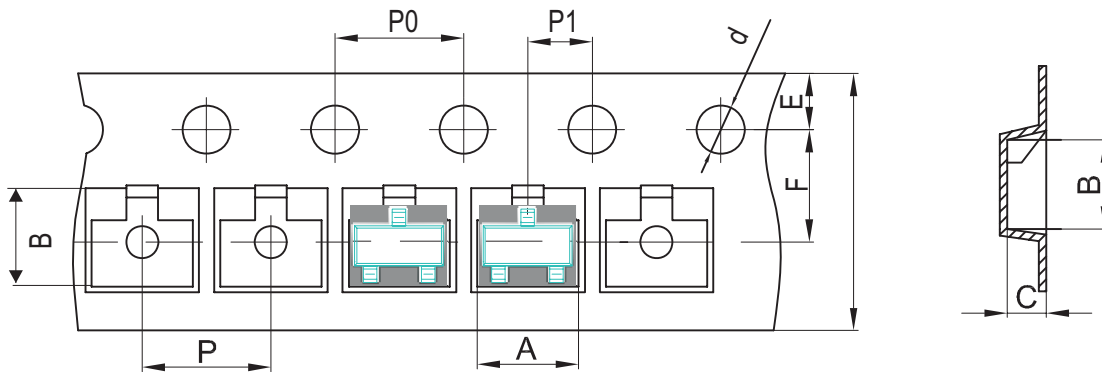

Fig.5 - $I_s - V_{SD}$



Company reserves the right to improve product design , functions and reliability without notice.

Reel Taping Specification



SOT-23	SYMBOL	A	B	C	d	D	D1	D2
	(mm)	3.15 ± 0.10	2.77 ± 0.10	1.22 ± 0.10	1.50 ± 0.10	178.00 ± 2.00	54.40 ± 1.00	13.00 ± 1.00
	(inch)	0.124 ± 0.004	0.109 ± 0.004	0.048 ± 0.004	0.059 ± 0.004	7.008 ± 0.079	2.142 ± 0.039	0.512 ± 0.039

SOT-23	SYMBOL	E	F	P	P0	P1	W	W1
	(mm)	1.75 ± 0.10	3.50 ± 0.10	4.00 ± 0.10	4.00 ± 0.10	2.00 ± 0.10	8.00 + 0.30 / - 0.10	12.30 ± 1.00
	(inch)	0.069 ± 0.004	0.138 ± 0.004	0.158 ± 0.004	0.158 ± 0.004	0.079 ± 0.004	0.315 + 0.012 / - 0.004	0.484 ± 0.039

Company reserves the right to improve product design , functions and reliability without notice.

Marking Code

Part Number	Marking Code
CJ3415-HF	R15

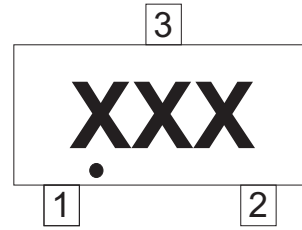

xxx = Product type marking code
 Solid dot = Halogen free parts

Suggested PAD Layout

SIZE	SOT-23	
	(mm)	(inch)
A	0.80	0.031
B	1.90	0.075
C	2.02	0.080
D	2.82	0.111

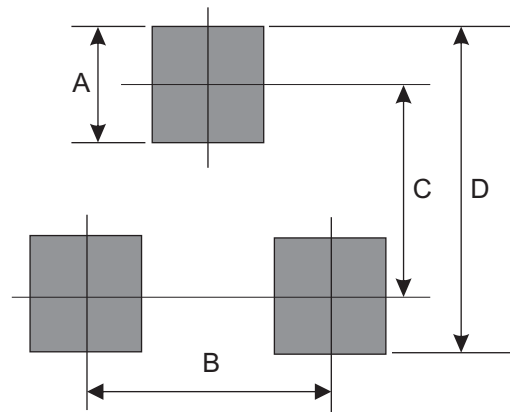

Standard Packaging

Case Type	Qty Per Reel	Reel Size
	(Pcs)	(inch)
SOT-23	3,000	7